

# Control of distributed and of hierarchical discrete-event systems

Jan H. van Schuppen (CWI/TUD)  
with Jan Komenda (CAS.IM) and Tomáš Masopust (CWI)

Centrum voor Wiskunde en Informatica (CWI), Amsterdam

2 September 2010  
DISC Workshop with North American Colleagues  
TUB, Berlin, Germany

# DISC Project

## DISC Project

- Supervisory control of large-scale plants (DISC).
- European Commission provides financial support in part (INFSO-ICT 224498).  
FP7, ICT Program, Theme Challenge 3: Components, Systems, Engineering,  
Objective ICT-2007.3.7 Networked Embedded and Control Systems  
(c) Control of Large-Scale Complex Distributed Systems.
- Coordinator is Alessandro Giua (U. Cagliari, Italy).
- Seven academic partners, three non-academic partners.
- Budget Costs EUR 2.9M, EU contribution EUR 1.9M.

## Teams and researchers

- Alessandro Giua, Carla Seatzu, Maria Paola Cabesino, Mauro Franceschelli (Ph.D. student).  
(University of Cagliari (CAG), Cagliari, Italy).
- Jan Komenda, Pavel Spacek.  
(Institute of Mathematics, Czech Academy of Sciences, Brno Branch (CAS), Brno, Czech Republic).
- JHvS, Rong Su (till 2010:08), Olivier Boutin (pd), Tomáš Masopust (pd).  
(Centrum Wiskunde & Informatica (CWI), Amsterdam, Netherlands).
- Eric Fabre, Philippe Darondeau, Stefan Haar, Serge Haddad, Loig Jezechiel (Ph.D. student) (INRIA/IRISA, Rennes, France).

## Teams and researchers - Continued

- Jörg Raisch, Tom Brunsch (PhD).  
(Technische Universität Berlin, Berlin, Germany).
- Manuel Silva, José Manuel Colom, Jorge Júlvez, Cristian Mahulea,  
Renato Vázquez, Hanife Aypaidin Ozkan, Lieiwei Wang (PhD students)  
(University of Zaragoza, Zaragoza, Spain).
- S. Goossens (Flemish government, Brussels, Belgium).
- Thomas Haenel (Cybio, Leipzig, Germany).
- Antonio Solinas, Luca Contini, Antonello Nieddu, Marco Pocci, Cristiano Poddi, Fausto Sessego (Akhela, Cagliari, Italy).

# DISC Project - Research

## DISC Workpackages

- WP0. Project management.
- WP1. Hierarchical modeling and abstractions.
- WP2. Fault detection algorithms.
- WP3. Coordination control of modular and distributed systems.
- WP4. Software platform.
- WP5. Case studies.
- WP6. Dissemination of the results.

# DISC Project - WP3 Control - Research efforts

## SWP3.1 Coordination control

Coordination control.

- INRIA: Distributed optimal planning. Distributed computation for weighted automata. Distributed control of coupled Markov processes. Distributed control of Petri nets.
- TUB: Consensus-based cooperative control systems.  $l$ -complete approximations for distributive control.
- UNIZAR: Distributed Petri nets - reachability for a marking. Distributed timed Petri nets. Deadlock free routing algorithms.
- U.GENT: Coordination control of urban traffic networks.
- CAS and CWI. See below.

## SWP3.2. Modular control with coordination control

## SWP3.3. Decentralized control with communicating controllers

- TUB: Cooperative control systems.
- UNIZAR: Communicating distributed Petri nets.
- CAS and CWI: See below.

# Table controller of MRI scanner

System view Engineering SCS Tools Applications Conclusions Philips

## Real-time control of a patient support system

Supervisory control synthesis using:

- modular supervisory control
- state-based supervisory control

Uncontrolled system: 6.3 billion states

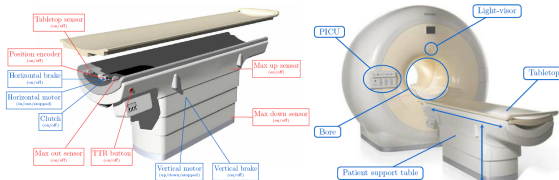

Bert van Beek, Industry Day FMWeek

Supervisory control synthesis

14/19

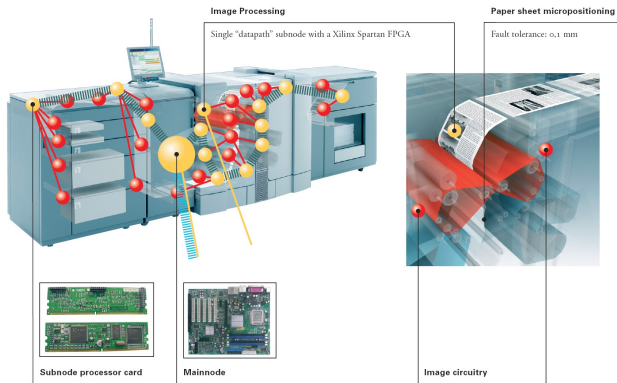

# Control of printers

## Control Architecture

9/14

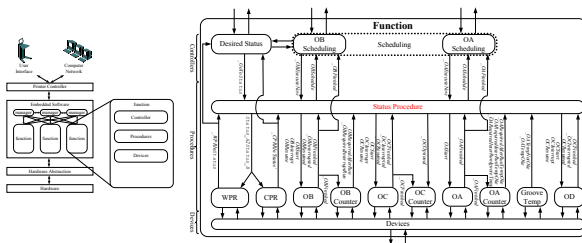

- ▶ Status procedure coordinates cleaning procedures (OA, OB, OC, and OD)
- ▶ Goal: Generate control software for the **status procedure**

# Control engineering

## Credit

- Koos Rooda and Bert van Beek, post-docs, and Ph.D. students (Eindhoven University of Technology, Eindhoven, The Netherlands).
- The DARWIN project, carried out under the responsibility of the Embedded Systems Institute with Philips Healthcare as carrying industrial partner, and supported by the Dutch Ministry of Economics Affairs under the BSIK program.
- Océ (Venlo, The Netherlands).
- European Commission for EU.ICT Project Control for coordination of distributed systems (C4C).

# Distributed and hierarchical systems

## Examples of distributed systems

- Control of automated guided vehicles (AGVs) on the HNN container terminal (C4C Project).
- Communication system. Sender and receiver. Alternating bit protocol.
- Communication networks, routing.

## Examples of hierarchical systems

- Océ printers (C4C.TUE).
- Philips MRI scanner table (TUE).

# Distributed DES

## Def. Distributed discrete-event system (DDES)

An interconnection of two or more discrete-event subsystems, each subsystem having inputs and outputs in the form of observable event streams.

## Remark

Distinguish:

- **Distributed DES** Interconnection of two or more subsystems.
- **Decentralized DES** a monolithic system with two or more observation streams and as many controllers.

Decentralized DES considered in the past were often distributed DES.

# Control of distributed DES

## Problem. Control of distributed DES

Synthesize a set of supervisors such that the associated closed-loop system satisfies the control objectives.

Examples of control objectives:

- **Safety**. Closed-loop language contained in the legal language.
- **Required behavior**. Closed-loop language contains the required behavior.
- **Nonblockingness**. From each state one can reach a marked state. Relevant for control of AGVs on container terminal.
- **Fairness**. All subsystems do progress eventually.  
In finite string framework, limit to be set.  
Infinite string framework more natural.
- **Performance**.

# Structure of DDES

## Structure of DDES

- Distributed discrete-event systems (DDES) are structured by construction.
- In many control engineering systems the structure is exploited.

## Def. Forms of structured DDES

- Fully distributed DES.
- Coordinated DDES.
- Distributed DES and communication between supervisors.
- Hierarchical DES.

# Fully distributed DES

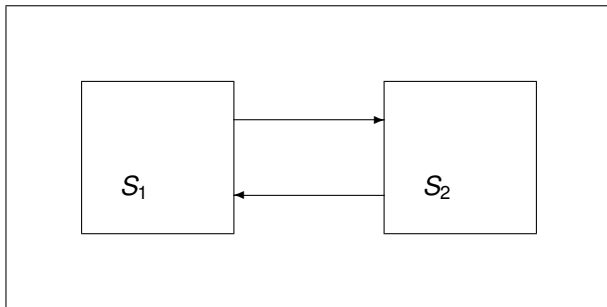

# Fully distributed DES with supervisors

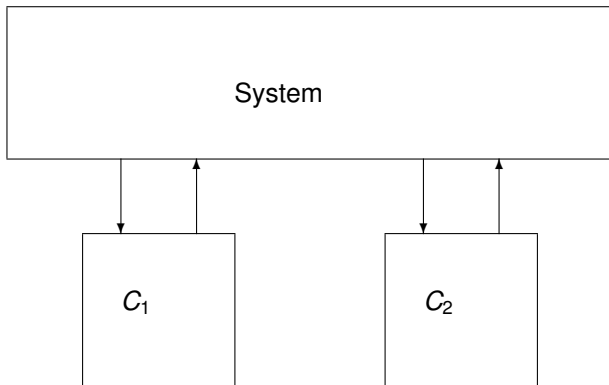

# Coordinated distributed DES

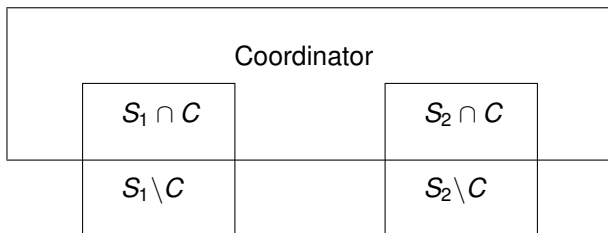

# Coordinated distributed DES

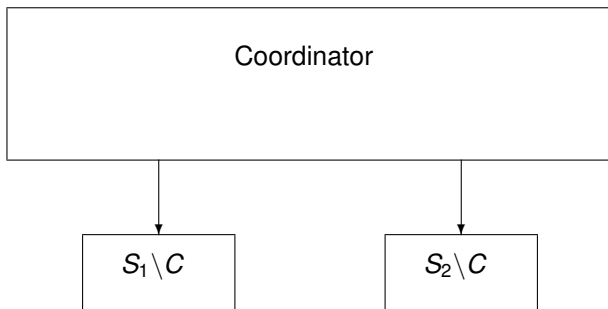

# Control of DDES with communication

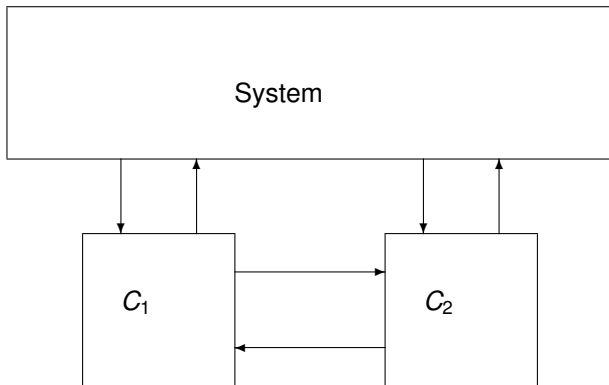

# Hierarchical DDES

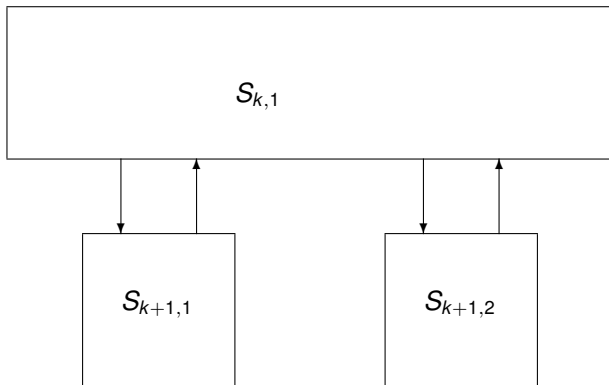

# Structure of DDES

## How to compute the structure?

- Modeling allows the formulation of a structured DDES.
- Computation for decomposition based on controllability and observability algorithms. To be explored.  
Computation of coordinated linear systems, see (P. Kempker, JHvS, A.C.M. Ran, (ECC.2009)).
- Author does not propose to compute all irreducible subsystems.

## Control synthesis

- Control synthesis has to be phrased in terms of the structure of the DDES.
- New concepts of controllability and of observability have to be formulated.

# Distributed control of DDES

## Problem. Control of a fully distributed DES

Consider:

- A distributed discrete-event system.
- Two or more streams of observed events.  
Observation alphabets are incomparable.
- A legal language.

Synthesize a set of supervisors such that the closed-loop language of the plant and the supervisors:

- 1 either equals the legal language;
- 2 or is a maximal element within the legal language.

Control synthesis of other control objectives to be considered also.

# Distributed control of DDES

## Control issues

- 1 What is the **state of the supervisor**?  
It should be a compression of the observed partial observations and of the dynamic systems influencing the distributed system. Uncertainty about the inputs of the other supervisors. See below.
- 2 **Equivalent condition** for the closed-loop system to equal the specification language.
- 3 In case the specification language does not satisfy the condition, then determine a sublanguage of the specification language. Concept of **maximal element**. See next slide.

# Distributed control of DDES

## Problem

$$\sup_{(g_1, g_2) \in G_1 \times G_2} J(g_1, g_2).$$

$g_i$  supervisor  $i$ ,  $i = 1, 2$ ,  
 $J(g_i, g_j)$  closed-loop language.

## Comments

- No solution procedure for this problem.  
Dynamic programming not applicable.
- Joint optimal control problem over the space of all supervisors.
- The partial observations of the two supervisors differ.

# Distributed control of DDES

## Def.

Person-by-person equilibrium  $(g_1^*, g_2^*) \in G_1 \times G_2$ ,  
(in game theory called a Nash equilibrium) if

$$J(g_1^*, g_2^*) = \sup_{g_1 \in G_1} J(g_1, g_2^*),$$

$$J(g_1^*, g_2^*) = \sup_{g_2 \in G_2} J(g_1^*, g_2).$$

## Comments

- Choice needed of sets of control laws,  $G_1$ ,  $G_2$ .  
Any supervisor must formulate assumption on complexity of the other supervisors.
- Concept of state of supervisor now clear,  
but depends on the choice of the set of control laws.
- If one supervisor of an equilibrium is specified, say  $g_1^* \in G_1$ ,  
then one obtains a control problem for only the remaining

# Distributed control of DDES

## Problems for maximal sublanguage

- Is a person-by-person equilibrium a maximal element?  
Note that there is no communication between the supervisors.
- How to determine an equilibrium?
- Uniqueness of equilibria and of maximal elements?  
Effects of non uniqueness?

## Remarks

- Distributed control of a DDES is with two or more supervisors.
- Special case of [dynamic game problem](#).
- Special case of a [dynamic team problem](#).  
A team problem is a special case of a game problem in which all players/supervisors have the same control objective.

# Distributed control

## Overview of results

- Equivalent condition for solvability, **co-observability**. (K. Rudie, W.M. Wonham, 1992).
- **Maximal elements** and a **strong Nash equilibrium**. (A. Overkamp, JHvS, 2000).
- Concept of **global mutual controllability** of modular systems. (J. Komenda, JHvS, 2007).

## Further research

- Interpretation of co-observability.
- Synthesis of control laws via equilibrium.
- Complexity and decidability.
- Signaling of private information via the plant.

# Coordination control

## Motivation

- Fully distributed control often cannot meet the control objectives.
- Forms of coordination are used in engineering control systems.
- Examples:
  - Communication via a channel.
  - High-speed printers (Océ).

# Coordination control

## Def. Coordinated DDES

$$G_k = (Q_k, E_k, f_k, q_{k,0}, Q_{k,m}),$$

$$G_1 = (Q_1, E_1, f_1, q_{1,0}, Q_{1,m}),$$

$$G_2 = (Q_2, E_2, f_2, q_{2,0}, Q_{2,m}),$$

$$\text{if } (G_1 \parallel G_2) : \xrightarrow{e} \Rightarrow e \in L(G_k).$$

Implies older definition (JK+JHvS (WODES.2008)).

# Coordination control

## Def. Conditionally independent languages

(a) Event characterization

$$L_1 \subseteq E_1^*, L_2 \subseteq E_2^*, L_k \subseteq E_k^*,$$

$L_1, L_2$  **conditionally independent languages** given  $L_k$  if

$$E_r(L_1 \parallel L_2) \cap E_1 \cap E_2 \subseteq E_k.$$

Notation  $(L_1, L_2 | L_k) \in \text{CIL}$ .

(b) **Conditionally shuffle closed**

$$\begin{aligned} & \dots (e_k, s)^* \in L_1 \parallel L_2 \parallel L_k, \quad e_k \in E_k, \quad s \in ((E_1 \cup E_2) \setminus E_k)^*, \\ \Rightarrow & \dots (e_k, \text{shuffle}(P_{1 \setminus k}(s), P_{2 \setminus k}(s)))^* \in L_1 \parallel L_2 \parallel L_k. \end{aligned}$$

# Coordination control

## Problem. Control synthesis

Consider

$$(G_1, G_2 | G_k) \in \text{CIG},$$

$$K \subseteq L(G_1 \| G_2 \| G_k), \text{ conditionally decomposable,}$$

$$K = P_{1+k}(K) \| P_{2+k}(K) \| P_k(K).$$

$$E_{i,u} = E_i \cap E_u, \quad i = k, 1, 2.$$

Construct supervisors  $(S_k, S_1, S_2)$  such that

$$K = L(S_1 / [G_1 \| (S_k / G_k)]) \| L(S_2 / [G_2 \| (S_k / G_k)]) \| L(S_k / G_k).$$

Note the subsystem

$$L(S_1 / [G_1 \| (S_k / G_k)]).$$

# Coordination control

## Def. Conditional controllability

Prefix-closed languages only.

Call  $K \subseteq E^*$  **conditionally controllable** with respect to the generators and the subsets of uncontrollable events, if

$$(1) \quad P_k(K)E_{k,u} \cap L(G_k) \subseteq P_k(K).$$

Then there exists a nonblocking supervisor  $S_k$ ,

$$L(S_k/G_k) = P_k(K).$$

$$(2) \quad P_{k+1}(K)E_{k+1,u} \cap \\ \cap L(G_1 \parallel (S_k/G_k)) \cap ((P_k^{k+1})^{-1}(P_k^{k+2}(L(G_2 \parallel (S_k/G_k)))))) \\ \subseteq P_{k+1}(K);$$

$$(3) \quad \text{in (2) exchange (1,2) } \Leftrightarrow \text{(2,1).}$$

# Coordination control

## Theorem. Existence supervisors

Consider the problem of control synthesis.  
There exists supervisors such that

$$K = L(S_1/[G_1 \parallel (S_k/G_k)]) \parallel L(S_2/[G_2 \parallel (S_k/G_k)]) \parallel L(S_k/G_k),$$

if and only if  
the specification language  $K$  is  
conditionally controllable with respect to the generators and the  
subsets of uncontrollable events.

(J. Komenda, T. Masopust, JHvS, WODES.2010).

Computational savings for computation of the supremal supervisor

$$\begin{aligned} & O(n(G_1)n(G_2)n(G_k)n(P_{1+k}(K))n(P_{2+k}(K))n(P_k(K))) \\ > & O(n(G_k)n(P_k(K)) + n(G_1)n(P_{1+k}(K)) + n(G_2)n(P_{2+k}(K))). \end{aligned}$$

# Coordination control

## Further results

- Supremal conditionally-controllable sublanguage. Existence and construction of supervisor.
- Conditional observability and conditional normality.
- Supervisory control synthesis with partial observations of a coordinated generator.
- Coordination control with nonprefix-closed languages.

## Plan

- Examples of engineering coordination control problems.
- Computation of structure.
- Nonblockingness in coordinated DDES.
- Characterization of minimality of coordinators.

# Control with communication

## Example 1. Alternating bit protocol of communication networks

Consider a communication system with a sender, a channel, and a receiver.

There are two supervisors, one at the sender and one at the receiver. Observations of supervisors at sender and receiver differ.

- A message is sent from the sender via the channel.
- The message is received by the receiver.
- Acknowledgement sent by receiver to the sender via the same or another channel. (This is the communication from one supervisor to another.)
- If the supervisor does not receive an acknowledgement within a set period then it resends the message.  
If the supervisor at the sender receives the acknowledgement then it sends the next message.

# Control with communication

## Problem. Control of DDES with communication

Consider a distributed DES.

Construct:

- 1 A communication supervisor which specifies which information of a supervisor should be sent to which other supervisors.
- 2 A control supervisor which uses the information of all received events to attain the control objectives.

## Remarks

- Distributed control of DDES often cannot meet the control objectives sufficiently well.
- Forms of communication are used in engineering systems.

# Control with communication

## Communication forms

- 1 **Subset communication.** All events in a subset of the observation alphabet are communicated to a prespecified supervisor. Very high computational complexity, Kurt Rohloff and JHvS (2005).
- 2 **Specified communication.** Specified events only are communicated.
- 3 **Supervisor requests communication.** George Barrett and Stéphane Lafortune (2000).
- 4 **Notification communication.** Supervisor who has knowledge communicates the information to other supervisors if perceived as useful. Laurie Ricker and Karen Rudie (1999).

# Control with communication

## Control issues

- 1 How should a supervisor interleave information of different sources?
- 2 What is the state space of a supervisor receiving communication directly from the plant and from one or more other supervisors?
- 3 How to determine a maximal element? How to determine an equilibrium which is a maximal element?
- 4 Complexity issues:  
Complexity of communication.  
Complexity of computation with the received communication?

# Control with communication

## Overview of results

- One-directional communication only.  
Existence of supervisor. No algorithm.  
Kai C. Wong and JHvS (1996).
- Algorithms.  
George Barrett and Stéphane Lafortune (2000),  
Laurie Ricker and Karen Rudie (1999).
- Algorithms and complexity.  
Karen Rudie, Stéphane Lafortune, et al.
- Structure of algorithms.  
Laurie Ricker et al.

# Hierarchical control

## Motivation

- Large engineering systems often have a hierarchical structure.
- Examples. Telephone networks, communication networks, road networks, airline traffic networks.
- Hierarchical optimization studied by Kenneth J. Arrow and Leonid Hurwicz, communication via prices.
- Hierarchical control of dynamics systems with periodic coordination exists in the literature.
- Hierarchical systems by abstraction, see below.

# Hierarchical control

## **Problem. Hierarchical control of hierarchical DES**

Consider a hierarchical DES with at least two levels.  
At each level there are one or more subsystems.  
Consider control objectives.

Construct a set of controllers/supervisors one for each subsystem, such that the closed-loop hierarchical system meets the control objectives.

# Hierarchical control

## Modeling of hierarchical DES (HDES)

- 1 By abstraction.  
Define a relation, prove it is an equivalent relation,  
construct the co-set and the associate dynamics.  
Choices: Relation on the state set or the events? Equivalence  
relation?
- 2 Engineering modeling.  
Example of underwater or aerial vehicles.
- 3 Relation with mammillary systems of compartmental systems.

# Hierarchical control

## Concepts of hierarchical control

- Hierarchical control consistency.  
Peter Gaines, W.M. Wonham.
- Observer property.  
Kai C. Wong, W.M. Wonham.
- State-tree structure.  
Ma Chuan, W.M. Wonham.

## Control issues

- 1 Controllability and observability of HDES?  
State space formulation of concepts.
- 2 Coordination aspects in a HDES?  
In case two or more subsystems at one level.
- 3 Extension of state-tree structures.

# Further research for control of D+H.DES

## Plan

- Structure of distributed and of hierarchical DES.
- Control of fully distributed DES.  
Interpretation of co-observability. Concept of state. Choice of maximal element. Computation of maximal element.
- Coordination control.  
Issues of coordination. Communication activities.
- Control with communication.  
Interleaving observation streams, concept of state, communication synthesis, control synthesis.
- Control of hierarchical DES. Concepts and control synthesis.
- Examples of engineering control problems.  
Printers, communication networks, etc.

# Concluding remarks

## Acknowledgements

- DISC colleagues.
- Researchers in control of DES.
- European Commission for financial support in part via the EU.ICT Project DISC (INFSO-ICT 224498).